

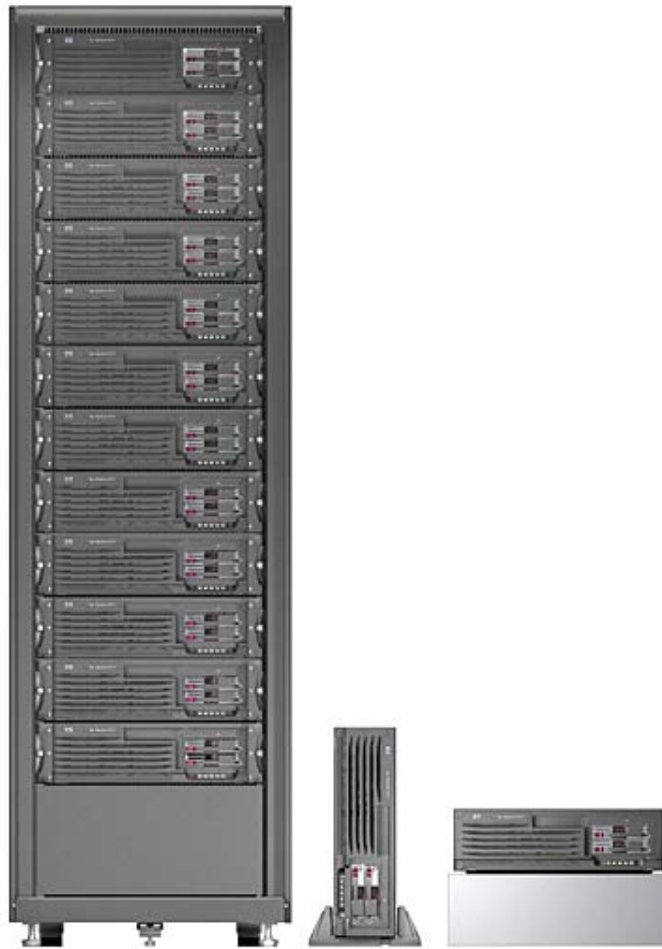

HP *AlphaServer* DS15 System Technical Summary



Contents

SYSTEM OVERVIEW 1

Features and Benefits 1

THIRD-GENERATION ALPHA CHIP 2

Alpha 21264C Features 2

ARCHITECTURE 3

System Block Diagram 3

MOTHER BOARD 4

Component and Connector Locations 4

MEMORY 5

SYSTEM I/O 6

Block Diagram of I/O Control 6

PCI Slots 6

I/O Ports 7

SYSTEM CONTROL 8

Control Panel 8

Storage 8

RAID (Redundant Array of Independent Disks) 8

SERVER MANAGEMENT 9

Operational Management 9

Platform Management 9

Error Reporting 9

SECURITY 9

RELIABILITY AND AVAILABILITY FEATURES 9

CLUSTERING 10

OPERATING SYSTEM SUPPORT 10

PERFORMANCE 10

SERVICE AND SUPPORT 11

Hardware Warranty 11

Software Warranty 11

ALPHASERVER DS15 SYSTEM DIAGRAMS 12

SYSTEM FEATURES AT A GLANCE 13

PHYSICAL CHARACTERISTICS 14

HP AlphaServer DS15 Systems

The *HP AlphaServer DS15* system is an entry-level system offering 64-bit computing with the Alpha processor. This single processor system is ideal for general purpose and commercial applications, telecom applications, software development, and replicated site applications. The 3U system box can be mounted in a cabinet or used on a desktop. A stand is available for convenient storage under or beside a desk.

System Overview

The *HP AlphaServer DS15* systems are available with a 1-GHz Alpha chip, the 21264C. Memory starts at 512 Mbytes and can be increased to 4 Gbytes. Second-level cache is 2 Mbytes. The switch-based system interconnect exploits the full potential of the Alpha chip.

The system measures 5.1 x 17.6 x 19.65 inches (3U) and can be placed on a desktop, desk side, or rackmounted in a choice of three rack cabinets (two M-Series and one 10000 Series), along with additional disks. In the largest cabinet (79 inches) up to 13 systems can be installed, or if more storage is desired, there can be up to six StorageWorks shelves and up to four systems.

A maximum of four drive bays are available when ordering the Front Access Storage Cage; three drive bays are available when ordering the Internal Storage Cage. Each storage cage includes a DVD/CD-RW drive. A 5.25-inch removable media device can be added to either storage cage, consuming one storage bay in the Internal Storage Cage and utilizing two storage bays in the Front Access Storage Cage. Up to 435.6-GB SCSI storage is available in systems with the Front Access Storage Cage and 218.2 GB in systems with the Internal Storage Cage.

There are four full-length PCI slots, four 64-bit slots @ 33 MHz or two 64-bit slots @ 66 MHz. Integrated on the system board are two 10/100 Mbit fast Ethernet controllers, two serial ports, two-port Ultra160 SCSI controller – one port supports internal devices, one port supports external devices, and keyboard and mouse ports.

Systems can be purchased with the Tru64 UNIX or OpenVMS operating systems installed.

For more information on *HP AlphaServer DS15* systems, see <http://h18002.www1.hp.com/alphaserver/>

Features and Benefits

Performance

The Alpha chip is offered with a switch-based interconnect that supports one 1 GHz processor and up to 4 Gbytes of memory. This switch-based system provides a memory bandwidth of up to 2.0 Gbytes/sec (peak) using a 128-bit memory bus running at 125 MHz. The peak I/O bandwidth is 792 Mbytes/sec.

Package and Price

The DS15 is packaged to provide ultimate configuration flexibility. The system package includes the base system and operating system; memory, disk and storage card cage are required selections. Users can build their own system, add it to their choice of rack cabinets, or add it to an existing cluster. Up to 13 DS15 systems can be mounted in a 79-inch cabinet.

DS15 Workstations

The 1-GHz system is also offered as a workstation and is called the AlphaStation DS15.

Third-Generation Alpha Chip

The third generation of the Alpha microprocessor, the Alpha 21264C, is a super-scalar, super-pipelined implementation of the Alpha architecture. The DS15 systems are offered with the EV68 (.18 micron) chip. Each chip has over 15.2 million transistors.

Designed for performance, the Alpha 21264C achieves this goal by carefully studied and simulated architectural and circuit analysis. The 21264C memory system also enables the high performance levels. On-chip and off-chip caches provide for very low latency data access, which allows for very high bandwidth data access. (The size of the off-chip cache is 2 Mbytes per processor running at 250 MHz DDR.)

Internal to each chip is a 64-Kbyte instruction cache (I-cache) and a 64-Kbyte data cache (D-cache).

- **I-cache.** 64 Kbytes, two-way set-associative, virtually addressed cache with 64-byte blocks
- **D-cache.** 64 Kbytes, two-way set-associative, virtually indexed, physically tagged, writeback cache with 64-byte blocks

Chip Operation

Several key design choices were made in the chip architecture to maximize performance: Four instructions are fetched each cycle, and then how those instructions are handled boosts the speed of execution. Register renaming assigns a unique storage location with each write reference to a register, avoiding register dependencies that can be a potential bottleneck to processor performance.

Another design feature, out-of-order execution, permits instructions to execute in an order different from the order that the instructions are fetched. In effect, instructions execute as soon as possible. This allows for faster execution since critical path computations are started and completed as soon as possible.

In addition, the Alpha 21264C employs speculative execution to maximize performance. It speculatively fetches and executes instructions even though it may not know immediately whether the instruction will be on the final execution path. This is particularly useful, for instance, when the 21264C predicts branch directions and speculatively executes down the predicted path. The sophisticated branch prediction in the 21264 coupled with the speculative and dynamic execution extracts the most instruction parallelism from applications.

For more information about the chip, see

<http://h18002.www1.hp.com/alphaserver/download/ev6chip.pdf>

Alpha 21264C Features

- Out-of-order instruction execution
- 64 Kbytes on-chip data and instruction caches
- Improved branch prediction through intuitive execution
- Register renaming
- Increased bandwidth for high-speed access to second-level cache and system memory
- Motion video instructions
- Square root and divide instructions
- All instructions are 32 bits long and have a regular instruction format
- Floating-point unit, supports DIGITAL and IEEE floating-point data types
- 80 integer registers, 64 bits wide
- 72 floating-point registers, 64 bits wide

Architecture

This system is designed to maximize the potential of the Alpha 21264C chip. The traditional bus interconnect has been replaced by a switch-based interconnect system. With a bus design, the processors, memory, and I/O modules must share the bus. As the number of bus users increases, the transactions interfere with one another, increasing latency and decreasing aggregate bandwidth. However, with a switch-based system there is no degradation in performance as the number of CPUs, memory, and I/O users increase. Although the users increase, the speed is maintained.

With a switch-based, or point-to-point interconnect, the performance remains constant, even though the number of transactions multiplies. The switched system interconnect uses a set of complex chips that route the traffic over multiple paths. The chipset consists of one C-chip, two D-chips, and one P-chip.

- **C-chip.** Provides the interface from the CPU and main memory.
- **D-chips.** Provide the data path for the CPU, main memory, and I/O.
- **P-chip.** Provides the interface to two independent 64-bit PCI buses.

The DS15 system supports one CPU and up to 4 Gbytes of memory. There are two memory arrays, each with two slots.

One 128-bit memory bus supports the two memory arrays, yielding 2 Gbyte/sec system bandwidth. Transactions are ECC protected. Upon the receipt of data, the receiver checks for data integrity and corrects any errors. Commands and addresses are parity protected.

System Block Diagram

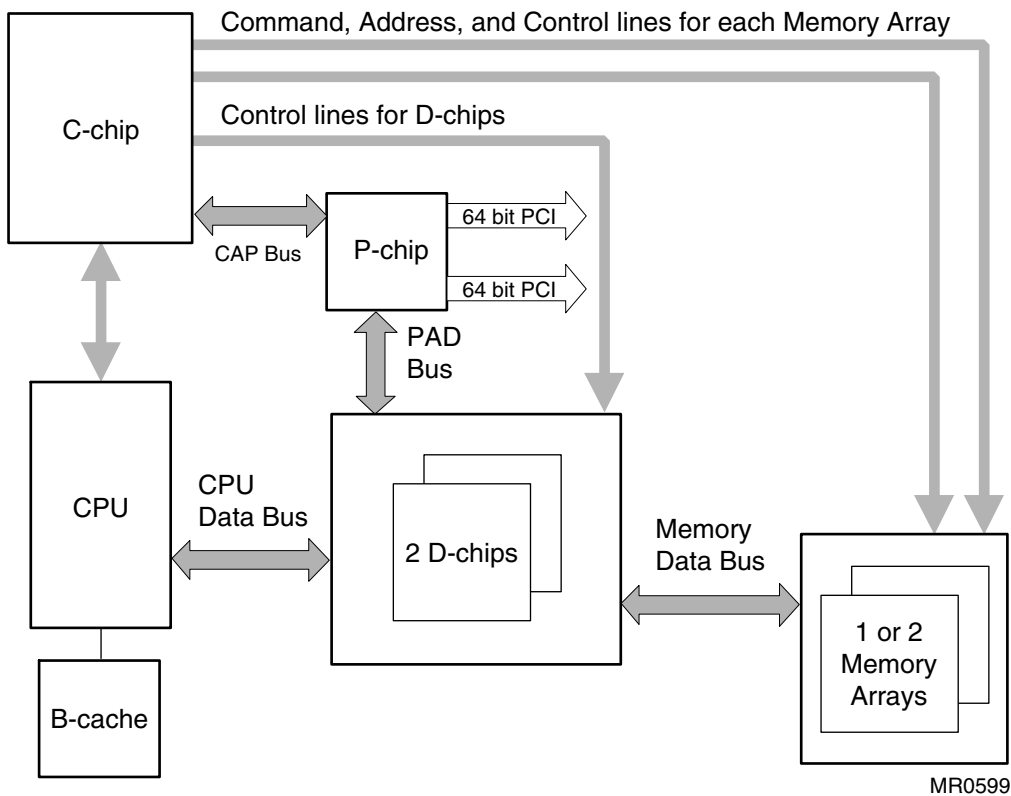

Mother Board

The interconnect switch is implemented on the system board by the chipset consisting of one C-chip, one P-chip, and two D-chips. The chipset provides the data and address path between the CPU, memory, and the I/O subsystem.

The CPU installed on the system board is the Alpha 21264C (1 GHz). The five cache chips provide 2 Mbytes of second-level cache. A flash ROM holds the SRM console code and the NVRAM data. The remote management console (RMC) is implemented by the RMC processor and is accessed through the COM1 port. Integrated into the system board is the logic

needed for all the ports shown on the module, including two Ethernet ports, dual-port Ultra160 controller, and one IDE connector for DVD/CD-RW only.

Jumpers on the board allow users to change the action of the Halt button and disable the RMC timer.

Connectors are on the system board for five other cards: the PCI riser card and four memory DIMMs.

Component and Connector Locations

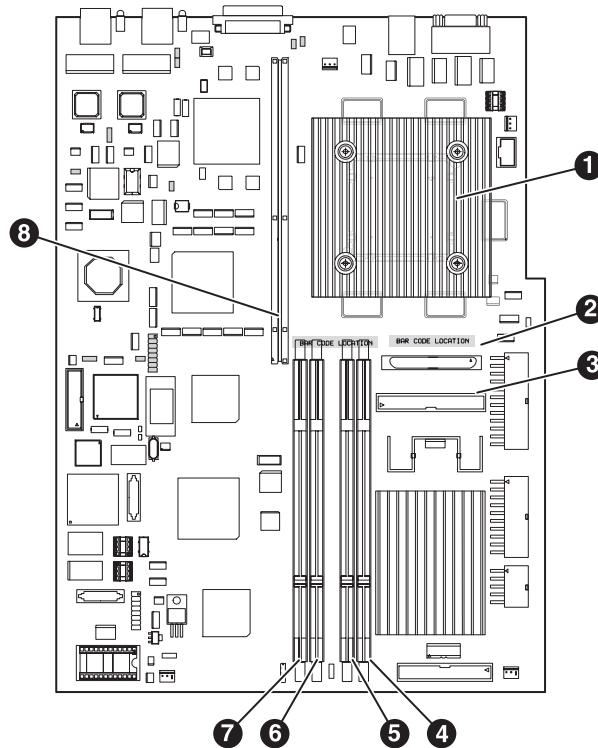

MR0555

1 CPU

2 Internal SCSI connector

1. CPU
2. Internal SCSI connector
3. IDE connector
4. Memory DIMM slot – array 2, DIMM 2
5. Memory DIMM slot – array 0, DIMM 0
6. Memory DIMM slot – array 2, DIMM 3
7. Memory DIMM slot – array 0, DIMM 1
8. PCI riser slot

Memory

Memory throughput is maximized by the following features:

- 128-bit wide memory data bus
- Very low memory latency (120 ns) and high bandwidth with 12 ns clock
- ECC memory

The switch interconnect can move a large amount of data over the memory data bus. The data bus is 128 bits wide (16 bytes). With the memory bus speed of 125 MHz, the maximum bandwidth is 2 Gbytes/sec.

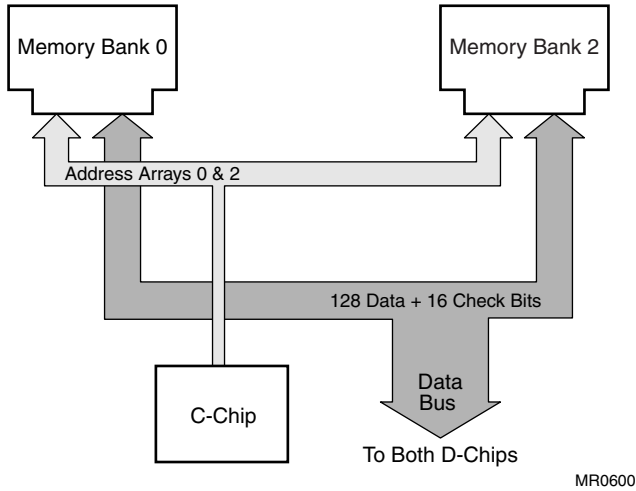

Memory Options

Each memory option consists of two 200-pin industry-standard DIMMs. The DIMMs are synchronous DRAMs. Memory options are available in the following sizes:

- 512 Mbytes (256 MB DIMMs)
- 1 Gbyte (512 MB DIMMs)
- 2 Gbytes (1 GB DIMMs)

The system supports 4 Gbytes of memory.

Memory Configuration

- Systems include one memory option (two DIMMs) installed in Bank 0.
- Both DIMMs in a bank must be the same type and size.
- A second set of DIMMs can be added.

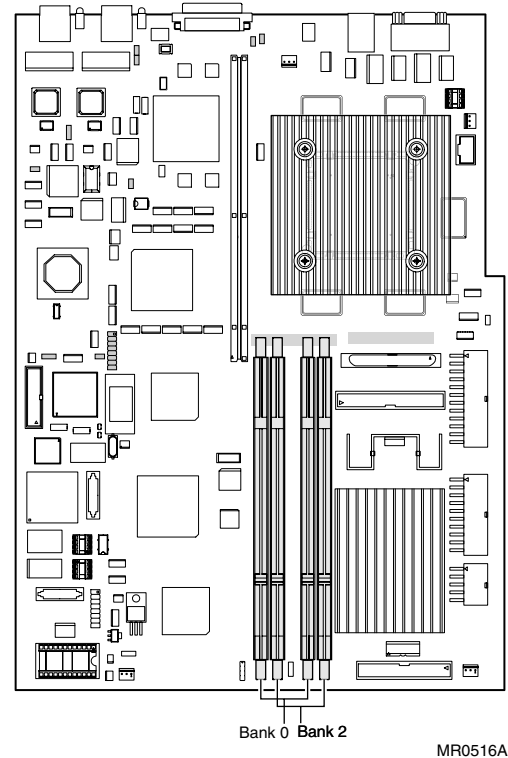

Memory Performance Considerations

With one memory option (2 DIMMs), memory operation interleaving will not occur. With two memory options (four DIMMs of the same size), memory read-write operations are two-way interleaved. Interleaved operations reduce the average latency and increase the memory throughput over non-interleaved operations.

System I/O

The industry-standard PCI bus is the number one choice for high-performance I/O options, such as disk storage and high-performance video applications.

The PCI bus implementation has the following characteristics:

- Fully compliant with the PCI Version 2.1 Specification
- Two PCI buses
 - One bus operates at 33 MHz, delivering a peak bandwidth of 264 Mbytes/sec.
 - One bus operates at 66 MHz, delivering a peak bandwidth of 528 Mbytes/sec.
- Supports three address spaces: PCI I/O, PCI memory, and PCI configuration space
- Supports byte/word, tri-byte, and longword operations
- Exists in noncached address space only

Block Diagram of I/O Control

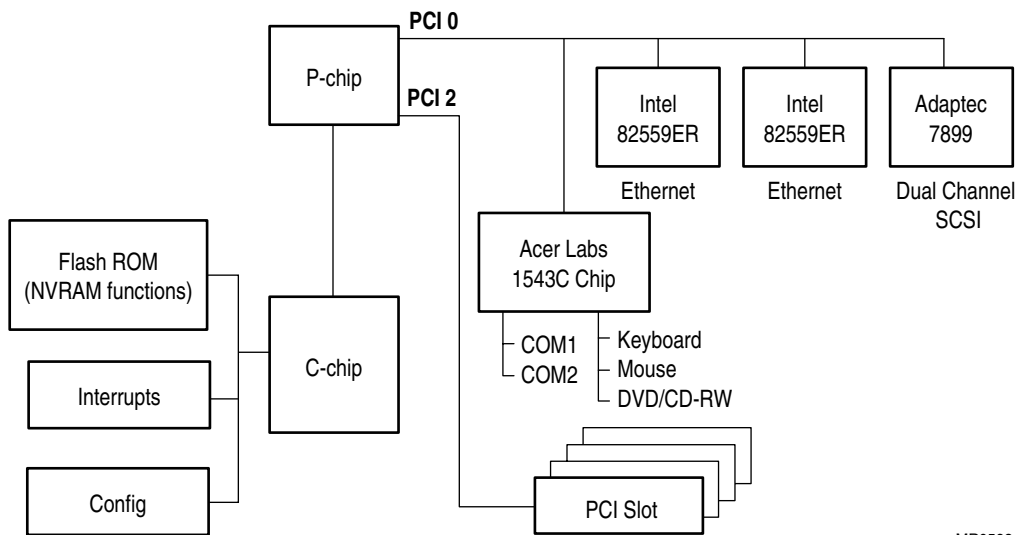

MR0598

The industry-standard PCI I/O bus allows the use of inexpensive, widely available I/O options. Both 32-bit and 64-bit PCI options can be used; only 3.3V options are supported. The Acer Labs 1543C chip provides the bridge from the PCI to lower level bus functions. The C-chip controls accesses to memory on behalf of the P-chip. Two chips – Intel 82559ER Ethernet and Adaptec 7899 SCSI – provide control for the two integrated Ethernet ports and the internal and external SCSI ports respectively.

On the PCI riser card there are four 64-bit PCI slots. When using 66-MHz options in slots 1 and/or 2, and no cards are installed in slots 3 and/or 4, the bus will operate at 66 MHz. When a 33 MHz option is added in any slot, the bus will operate at 33 MHz. In addition, the bus will operate at 33 MHz if a PCI option is plugged into slot 3 and/or 4 (regardless of the speed of the option).

PCI Slots

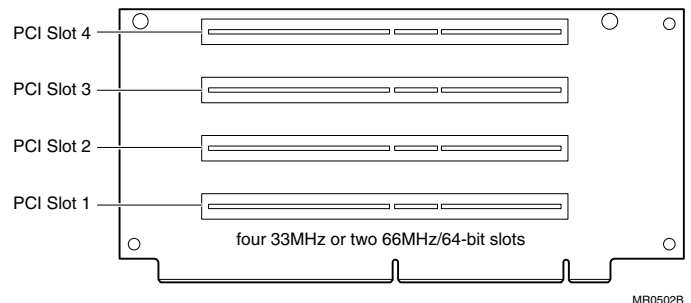

MR0502B

I/O Ports

At the rear of the system are connectors offering access to two serial communication ports, one SCSI port, two Ethernet ports, and ports for the keyboard and mouse. (The USB ports are not supported.) The COM1 port is used for the system console and for the remote management console.

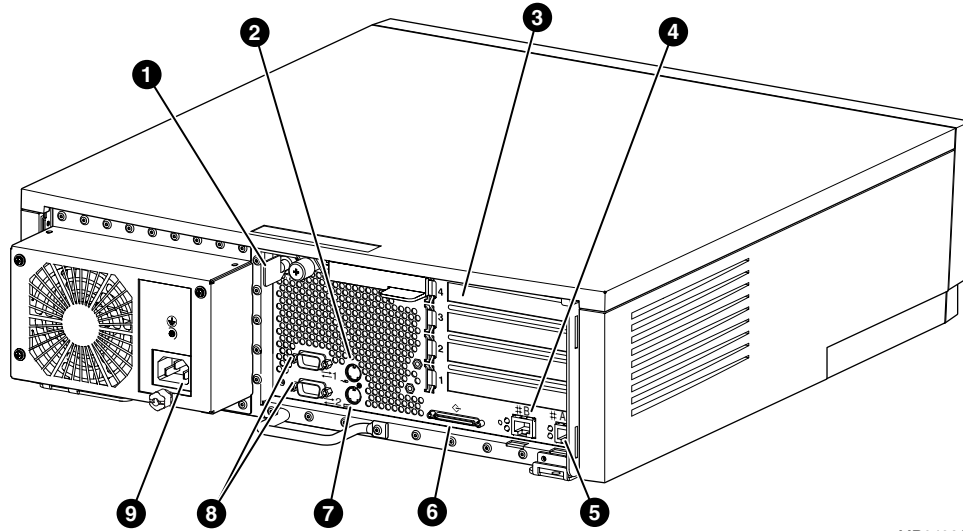

MR0498C

1. Key
2. Mouse connector
3. PCI slots
4. Ethernet port B
5. Ethernet port A
6. SCSI connector
7. Keyboard connector
8. COM 1 serial port (top), COM 2 serial port bottom
9. Power connector

System Control

Close monitoring and control of the system environment and hardware is accomplished by the remote management console (RMC). This logic allows the system operator to perform console operations remotely using a dial-in modem. The RMC logic is implemented using a Zircon microprocessor on the system board. The RMC firmware code resides in flash memory. The RMC is powered by an auxiliary 5V supply, so even when the system is powered off at the control panel the RMC can be accessed—so long as the system is plugged in.

The RMC provides the following monitoring and control functions:

- Monitors thermal sensors, the power supply, and fans
- Detects alert conditions such as excessive temperature, fan failure, and power supply failure and sends an alert
- Performs remote power on/off, halt, and reset
- Dials a pager phone number or another computer system to notify the remote operator of an alert condition
- Shuts down the system if any fatal conditions exist

Upon an environmental event, the reason for failure is stored in the RMC NVRAM; the data can be retrieved to aid in diagnosing the problem.

Control Panel

The system control buttons and indicator LEDs are located in the lower right corner on the front of the system.

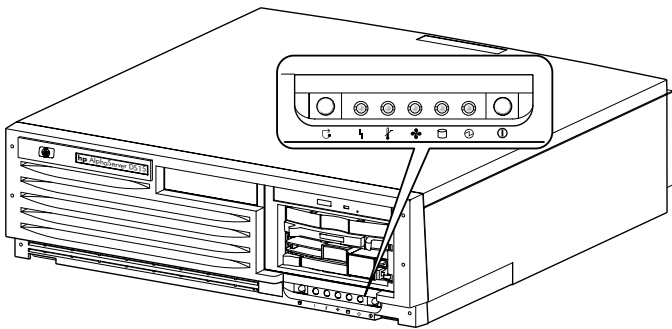

The operation of the button at the left depends upon the setting of a jumper. It functions as a Halt or Reset button.

Storage

The DS15 is available with either an Internal Storage Cage or a Front Access Storage Cage. The Internal Storage Cage systems include four storage bays – DVD/CD-RW and three storage bays: three internal 3.5-inch x 1-inch hard disk drives or two internal 3.5-inch x 1-inch hard disk drives and one 5.25-inch x 1-inch removable media device.

The Front Access Storage Cage systems include five storage bays – DVD/CD-RW and four storage bays: two front access 3.5-inch x 1-inch hard disk drives and two internal 3.5-inch x 1-inch hard disk drives) **or** one 5.25-inch x 1.6-inch removable media device and two internal 3.5-inch x 1-inch hard disk drives.

Disks supported: 36.4-GB and 72.8-GB Wide Ultra3 available with the Internal Storage Cage, and 18.2-GB, 36.4-GB, 72.8-GB, or 146-GB Universal SCSI drives available with Front Access Storage Cage.

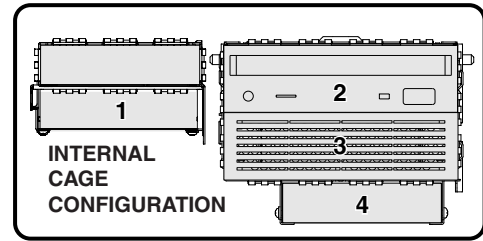

- | | |
|----------------------|-------------------------------|
| 1 Internal drive bay | 3 DVD/CD-RW or internal drive |
| 2 DVD/CD-RW | 4 Internal drive |

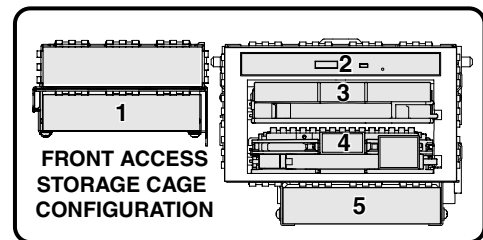

- | | |
|--------------------------|---------------------------------|
| 1 Internal drive bay | 3,4 Front access tape drive bay |
| 2 DVD/CD-RW | 4 Front access drive bay |
| 3 Front access drive bay | 5 Internal drive bay |

RAID (Redundant Array of Independent Disks)

The system can be configured with optional PCI RAID controllers to organize disk data cost-effectively, improve performance, and provide high levels of storage integrity. Today, RAID is only available with StorageWorks shelves.

The optional RAID controllers have the following features:

- Support for hot-swap drives
- Automatic rebuild after hot swap
- Console support for booting system from RAID
- RAID levels 0, 1, 0+1, 5
- Optional write cache
- Optional read cache
- Support for command queuing

Server Management

The *AlphaServer* products support important operational and platform management requirements.

Operational Management

Server/Network Management. Insight Manager is included with every system. This software tool allows you to monitor and control Alpha based servers. *Insight Manager* consists of two components: a Windows-based console application and server- or client-based management data collection agents. Management agents monitor over 1,000 management parameters. Key subsystems are instrumented to make health, configuration, and performance data available to the agent software. The agents act upon that data, by initiating alarms in the event of faults and by providing updated management information, such as network interface or storage subsystem performance statistics.

Remote Server Management. The integrated remote management console (RMC) lets the operator perform several tasks from a serial console: monitor the system power, temperature, and fans, and reset, halt, and power the system on or off. The monitoring can be done locally or remotely through a modem.

Platform Management

The AlphaServer DS15 systems support platform management tasks such as manipulating and monitoring hardware performance, configuration, and errors. For example, the operating systems provide a number of tools to characterize system performance and display errors logged in the system error log file.

In addition, system console firmware provides hardware configuration tools and diagnostics to facilitate quick hardware installation and troubleshooting. The system operator can use simple console commands to show the system configuration, devices, boot and operational flags, and recorded errors. Also, the console provides inventory support and configuration management by giving access to serial numbers and revisions of hardware and firmware.

Error Reporting

System Event Analyzer, a diagnostic service tool used to determine the cause of hardware failures, is installed with the operating systems. It provides automatic background analysis, as it constantly views and reads the error log file. It analyzes both single error/fault events and multiple events. When an error condition is detected, it collects the error information and sends it and an analysis to the user. The tool requires a graphics monitor for its output display.

Security

- The top cover can be locked with a key.
- Password protection is offered by the SRM console and RMC.

Reliability and Availability Features

The *AlphaServer* DS15 system achieves an unparalleled level of reliability and availability through the careful application of technologies that balance redundancy, error correction, and fault management. Reliability and availability features are built into the CPU, memory, and I/O, and implemented at the system level.

Processor Features

- CPU data cache provides error correction code (ECC) protection.
- Parity protection on CPU cache tag store.
- Multi-tiered power-up diagnostics to verify the functionality of the hardware.

Memory Features

- The memory ECC scheme is designed to provide maximum protection for user data. The memory scheme corrects single-bit errors and detects double-bit errors and total DRAM failure.

I/O Features

- ECC protection on the switch interconnect and parity protection on the PCI and SCSI buses.
- Extensive error correction built into disk drives.
- Optional RAID improves reliability and data security.

System Features

Auto reboot. On systems running Tru64 UNIX or OpenVMS, a firmware environment variable lets you set the default action the system takes on power-up, reset, or after an operating system crash. For maximum system availability, the variable can be set to cause the system to automatically reboot the operating system after most system failures.

Software installation. The operating systems are factory installed. Factory installed software (FIS) allows you to boot and use your system in a shorter time than if you install the software from a distribution kit.

Diagnostics. During the power-up process, diagnostics are run to achieve several goals:

- Provide a robust hardware platform for the operating system by ensuring that any faulty hardware does not participate in the operating system session. This maximizes system uptime by reducing the risk of system failure.
- Enable efficient, timely repair.

Audible beep codes report the status of diagnostic testing. The system has a firmware update utility (LFU) that provides update capability for console and PCI I/O adapter firmware. A fail-safe loader provides a means of reloading the console in the event of corrupted firmware.

Thermal management. The air temperature and fan operation are monitored to protect against overheating and possible hardware destruction. Four fans provide cooling. The system fan is located in the front center of the system box; another fan cools the PCI area. Also, a fan is mounted over the Alpha chip, and the power supply has a fan. If the temperature rises, the system fan, PCI fan, and/or the CPU fan speeds up, or if necessary to prevent damage, the system shuts down.

Error handling. Parity and other error conditions are detected on the PCI bus. The memory checking scheme corrects single-bit errors and detects double-bit errors. Multiple ECC corrections to single-bit errors detected by the operating systems help determine where in the system the error originated. Errors are logged for analysis.

Uninterruptible power supply. An external UPS can be purchased to support critical customer configurations. Because power is maintained for the entire system (CPU, memory, and I/O), power interruptions are completely transparent to users.

Clustering

A cluster is a loosely coupled set of systems that behaves (is addressed and managed) like a single system, but provides high levels of availability through redundant CPUs, storage, and data paths. Clusters are also highly scalable; that is, CPU, I/O, storage, and application resources can be added incrementally to efficiently increase capacity. For customers, this translates to reliable access to system resources and data, and investment protection of both hardware and software.

Clustering allows multiple computer systems to communicate over a common interface, share disks, and spread the computing load across multiple CPUs.

Operating System Support

For clustered *Tru64 UNIX* systems, TruCluster Software solutions allow users access to network services and provide further failover recovery from server, network, or I/O failures. *Tru64 UNIX* cluster systems use the SCSI bus between disks and systems.

OpenVMS cluster systems use SCSI, Ethernet, and FDDI as the interconnects between disks and the system.

The primary means of clustering AlphaServer DS15 systems depends on the operating system.

- Ethernet, OpenVMS
- SCSI clusters, Tru64 UNIX and OpenVMS

Performance

HP has an ongoing program of performance engineering, using industry-standard benchmarks that allow comparisons across major vendors' systems. These benchmarks against competitive systems are based on comparable CPU performance, coupled with comparable memory and disk expandability.

See Table 1 for the performance numbers of the AlphaServer DS15 systems. System performance, however, is highly dependent upon application characteristics. Thus, benchmark information is one helpful "data point" to be used in conjunction with other purchase criteria such as features, service, and price.

Information for Partners

Channel or Reseller Partners can find the tools, resources, and information needed to conduct business online at:

<http://welcome.hp.com/country/us/en/solutions/partners.html>

Service and Support

HP provides a comprehensive set of services that range from migration, consulting, and training, to direct support of Alpha systems, software, and applications. For information on services, see <http://www.hp.com/hps/>

Hardware Warranty

The *AlphaServer* DS15 system and components, including CPU, memory, PCI controllers, and power supplies, have a 1-year on-site, 5-day per week, 9-hour per day hardware warranty with next business day response time.

StorageWorks components are supported by the comprehensive StorageWorks warranty: five years for disks, three years for controllers, two years for tape devices, and one year for other components. The first year includes on-site next-day response time. Network products carry the network products warranty.

Users can upgrade to higher levels of service through a variety of hardware supplemental services.

Software Warranty

The warranty for *Tru64 UNIX* and *OpenVMS* is conformance to SPD with advisory telephone support for a period of 90 days. Users can upgrade to higher levels of service through a variety of software supplemental services.

AlphaServer DS15 System Diagrams

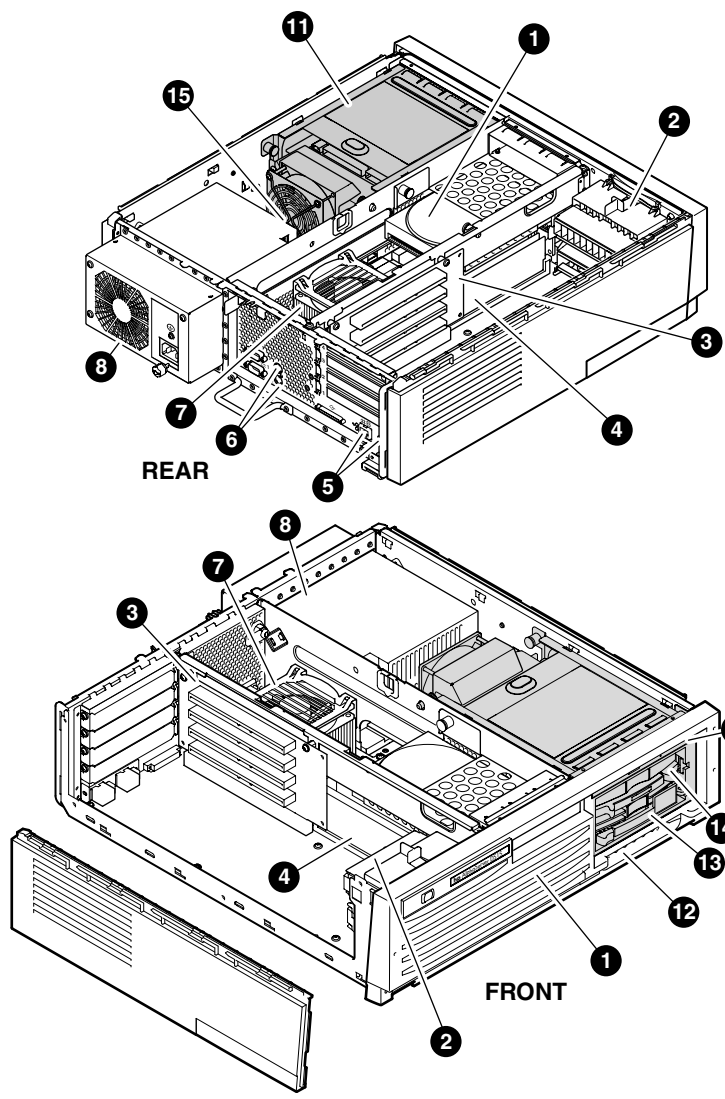

1. Concealed disk bay
2. Fan assembly
3. PCI riser card
4. Memory
5. Dual Ethernet ports
6. Keyboard and mouse ports
7. CPU and fan
8. Power supply
9. System disk
10. Optional disk, DVD/CD-RW or tape bay
11. DVD/CD-RW
12. Control panel
13. Front accessible disk
14. Optional front accessible disk
15. Disk fan

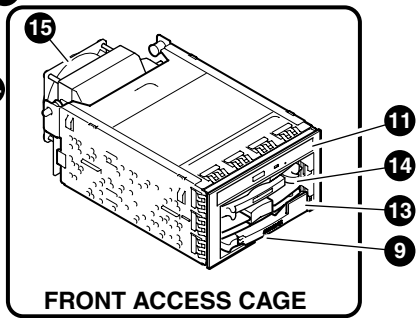
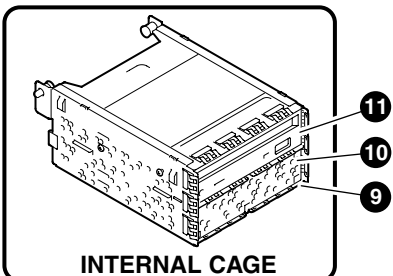

MR0546A

System Features at a Glance

Table 1 provides a quick reference to features of the *AlphaServer DS15* systems.

Table 1 *AlphaServer DS15* Features

CPU Features	
Processor	One Alpha 21264AC
CPU clock speed	1 GHz
Cache on chip	64 KB I-cache 64 KB D-cache
On-board cache	2 MB
Memory (maximum)	4 GB
Performance	68/1000
SPECint2000	592
SPECfp2000	813
SPECint_rate2000	6.87
SPECfp_rate2000	9.42
Linpack 100x100	825.3
Linpack (1kx1k)	1475
Standard Features	DVD/CD-RW, two 10/100-Mbit Ethernet ports, dual-port Ultra160 controller, two serial ports, (no parallel port), keyboard, mouse, integrated remote management console, rackmount slide kit, operating system license, customer documentation, Internet software
Internal Storage	
Removable media	DVD/CD-RW, optional tape drive
System storage	214.8 GB SCSI with Internal Storage Cage or 435.6 GB SCSI with Front Access Storage Cage
I/O System	
I/O slots	Four full-length 64-bit/33-MHz slots or two full length 64-bit/66-MHz slots
Maximum PCI throughput	528 MB/sec
High Availability Features	
System	Auto reboot, thermal management, remote management console, RAID, ECC memory, ECC cache, error logging, optional uninterruptible power source. Also with rackmount: multiple systems, multiple power sources, dual-ported storage
OpenVMS clusters	Ethernet, SCSI, FDDI
UNIX TruCluster Solutions	SCSI
Operating Systems	Tru64 UNIX, OpenVMS
Warranty	
Hardware	1-year, on-site, 5 day x 9 hour warranty with next business day response
Software	90-day conformance to Software Product Description, OpenVMS and Tru64 UNIX

Physical Characteristics

Table 2 details basic physical characteristics of the system.

Table 2 AlphaServer DS15 Physical Characteristics

Dimensions (H x W x D)	5.1 x 17.6 x 19 in (13 x 45 x 48 cm)		
Weight (maximum)	36 lb (16.3 kg)		
	H9A10 M-Series	H9A15 M-Series	
Dimensions (H x W x D)	67 x 23.6 x 36.1 in (170 x 60 x 91.6 cm)	79 x 23.6 x 36.1 in (200 x 60 x 91.6 cm)	
Shipping Dimensions	73 x 36 x 48 in (185.5 x 91.5 x 122 cm)	85 x 36 x 48 in (216 x 91.5 x 122 cm)	
Weight	Configuration dependent	1,000 lb/450 kg	
Shipping Weight	Configuration dependent, maximum payload	1,056 lb (550 kg) (normal) 1,408 lb (640 kg) (maximum)	
Environmental			
Temperature	Operating	10-40° C (50-104° F)	
	Nonoperating	-40 to 66° C (-40 to 151° F)	
Humidity (noncondensing)	Operating	10-90%	
	Nonoperating	10-95%	
Altitude (unpressurized)	Operating	3,048 m (10,000 ft)	
	Nonoperating	12,192 m (40,000 ft)	
Electrical			
Nominal voltage range	100–120 Vac / 220 Vac		
Operating voltage range (temporary condition)	90 to 128 Vac / 180–265 Vac		
Power source phase	Single / Single		
Nominal frequency	60 Hz / 50 Hz		
Frequency range	59 to 61 Hz / 49 to 51 Hz		
Maximum inrush current	11 amps / 22 amps		
Single power supply	3.5 amps / 1.7 amps		
Acoustics —Declared values per ISO 9296 and ISO 7779			
Current values for specific configurations are available from HP. 1 B = 10 dBA			
DS15 with 1 or 2 HDD	L _{wad} , B	L _{pAm} , dBA (operator position)	L _{pAm} , dBA (bystander positions)
Idle	5.6	49	39
Operating	5.7	50	40
Regulatory	Agency Approvals	UL: Listed to UL1950 (3rd edition) CUL Listed: CAN/CSA-C22.2 No. 950-M95 TUV: EN 60950/A11: 1997 GS marked FCC: Part 15 Class B CE: EN55022, EN50082 VCCI Class II ITE BMSI: CISPR22, CNS13438 C-Tick: CISPR22, AS/NZS 3548	
	Reviewed to	AS/NZ 3260:1993 Australian/New Zealand Standard EN 60950/A11: 1997 European Norm IEC950 (2nd edition, 4th amend)	

© Copyright 2004 Hewlett-Packard Development Company, L.P.
 The information contained herein is subject to change without notice.
 UNIX is a registered trademark or trademark of The Open Group in the U.S.
 and/or other countries. The only warranties for HP products and services are
 set forth in the express warranty statements accompanying such products and
 services. Nothing herein should be construed as constituting an additional warranty.
 HP shall not be liable for technical or editorial errors or omissions contained herein.

Revision 2 - April 2004